

OVAL WHEEL METER

SERIES OaP

1. IDENTIFICATION

Manufacturer	Bopp & Reuther Messtechnik Am Neuen Rheinhafen 4 67346 Speyer / Germany Phone: +49 6232 657-0 Telefax: +49 6232 657-505
Product type	Direct volumetric meter (positive displacement meter, version: double-case)
Product name	Oval Wheel Meter Series OaP

2. RANGE OF APPLICATION

The range of application of all oval wheel meters of the series OaP comprises measuring of volumes and flowrates in the process, custody transfer, dosage and controlling of liquids. They are used for the measurement of intermediate and final liquid products such as liquefied gases, acids, alkaline solutions, fats, alcohol, solvents, dispersions, polymers, polycondensates, paints, colors, adhesives and other media. Please note the oval wheel meters capability to measure liquids with very high viscosities with nearly no pressure loss.

The high accuracy provided by the oval wheel meters series OaP ensure a maximum quality of products being manufactured.

Oval wheel meters of the series OaP are manufactured with nominal widths of 25 to 400 mm. Depending on the nominal width they can be used up to PN100 with a maximum operating temperature of up to 290°C.

3. MEASURING PRINCIPLE AND SYSTEM CONFIGURATION

3.1 Measuring principle

Oval wheel meters belong to the group of direct volumetric meters for liquids with movable partition walls (displacement flow meters). The oval wheel meter consists of a measuring chamber housing with two pivoted oval wheels, which are toothed and roll off in counter-rotations around each other.

Each revolution of the oval wheels displaces four discrete volumes of fluid (defined by the space between oval wheel and measuring chamber) through the counter. The number of the rotations is a measure for the volume.



OVAL WHEEL METER

SERIES OoP

3.2 System configuration

Sensor:

Measuring of the volumetric flow and the volume of liquids is performed by the oval wheel meter either by.

- A magnetic coupling which transmits the rotation of the oval wheel to mechanical roller counters with the decisive advantage of having to work without auxiliary power, optionally with an encoder (e.g. AG19, AG01-08) for connection to flow computers, controls or control systems

or

- Via a direct electronic scanning of the rotation of the oval wheels by means of pulse generators (e.g. AG44) without further mechanical parts if necessary. With smart transmitter UST combined with the advantages of modern electronic solutions and indirect integration into control systems via 4-20mA / 2-wire technology / HART

For these oval wheel meters an extensive program of additional equipment is available as mechanical, pneumatic, electrical and electronic transducers whose signals for remote counting, flow measurements and controls, as well as for integration in higher-level automation systems can be used. Also applicable for dosing suitable quantity preselection devices with matching valves of different design and operation.

Pulse pick-up AG19 / AG20 see D-EN-17202-00
(attached devices acc. EN 50227 NAMUR)

Pulse pick-up AG01-08 see D-EN-17203-00
(attached devices acc. Open collector NPN)

Pulse pick-up AG44 see D-EN-17201-00
AG43 Wiegand-principle
(attached devices acc. EN 50227 NAMUR)

**Single indicator E and
Double indicator D** see D-EN-17205-00

**Mechanical resettable
roller counter M5** see D-EN-17205-00
M5 with presetting device
M5V
Step switches sp2 , sp22 , se2

Universal Smart Transmitter UST see D-EN-17207-00

The UST is equipped as standard with a local display, a 4-20 mA 2-wire current output for flow signal and HART-communication (FDT compatible driver available), and a separate pulse output for counting (original pulses or scaled pulses) according to NAMUR or 2-wire current pulse output instead of the analog 4-20mA current output

4. INPUT

4.1 Measured value

Volume and volume flow rate

OVAL WHEEL METER

SERIES OaP

4.2 Flow range

Type	DN	Flowrate Q _{max} [l/min]	Liability at viscosity	< 0.3 mPa·s		0.3 – 1.5 mPa·s		1.5 - 150 mPa·s		to 350 mPa·s		to 1000 mPa·s		to 3000 mPa·s	
				[l/min]	[m³/h]	[l/min]	[m³/h]	[l/min]	[m³/h]	[l/min]	[m³/h]	[l/min]	[m³/h]	[l/min]	[m³/h]
OaP5	25	60 (3.6 m³/h)	Min	8	0.5	5	0.3	5	0.3	2.5	0.15	1.25	0.075	0.45	0.027
			Max	48	3.0	60	3.6	60	3.6	30	1.8	15	0.9	5.4	0.32
			continuous	18	1.1	36	2.2	50	3	28	1.7	14	0.83	5	0.3
OaP10	25	120 (7.2 m³/h)	Min	16	1.0	10	0.6	10	0.6	7	0.42	3.5	0.20	1.2	0.072
			Max	96	6.0	120	7.2	120	7.2	84	5	42	2.4	14.4	0.86
			continuous	36	2.2	73	4.4	99	5.9	77	4.6	39	2.2	13.2	0.79
OaP50	50	360 (21.6 m³/h)	Min	50	3.0	30	1.8	30	1.8	18	1.08	9.0	0.54	3	0.18
			Max	300	18	360	21.6	360	21.6	216	13	108	6.5	36	2.2
			continuous	110	6.6	220	13	297	18	198	12	99	5.9	33	2
OaP125	65	840 (50.4 m³/h)	Min	100	6	70	4.2	70	4.2	60	3.6	40	2.4	15	0.9
			Max	600	36	840	50.4	840	50.4	720	43	480	29	180	11
			continuous	220	13	460	28	578	35	660	40	440	26	165	10
OaP250	80	1440 (86.4 m³/h)	Min	200	12	120	7.2	120	7.2	100	6	60	3.6	30	1.8
			Max	1200	72	1440	86.4	1440	86.4	1200	72	720	43	360	22
			continuous	440	26	790	48	1100	66	1100	66	660	40	330	20
OaP600	100	3600 (216 m³/h)	Min	400	24	250	15	250	15	200	12	150	9	75	4.5
			Max	2400	140	3600	216	3600	216	3000	180	1800	110	900	54
			continuous	880	53	1800	110	2750	165	2750	165	1650	100	830	50
OaP 1200	150 6"	6000 (360 m³/h)	Min	800	48	500	30	500	30	400	24	250	15	120	7.2
			Max	4800	290	6000	360	6000	360	4800	290	3000	180	1400	86
			continuous	1800	110	2800	170	3900	220	4400	260	2800	170	1300	79
OaP 2000	200 8"	9600 (576 m³/h)	Min	1300	80	800	48	800	48	660	40	400	24	200	12
			Max	7800	480	9600	576	9600	576	7900	480	4800	290	2400	140
			continuous	2900	180	4400	260	6100	350	7300	440	4400	260	2200	130
OaP 3200	300 12"	14400 (864 m³/h)	Min	2000	120	1200	72	1200	72	1000	60	600	36	300	18
			Max	12000	720	14400	864	14400	864	12000	720	7200	430	3600	220
			continuous	4400	260	6600	400	8800	530	11000	660	6600	400	3300	200
OaP 4000	400 16"	24000 (1440 m³/h)	Min	3200	200	2000	120	2000	120	1500	90	1000	60	400	42
			Max	19000	1200	24000	1440	24000	1440	18000	1100	12000	720	4800	290
			continuous	7300	440	11000	660	15000	880	17000	1000	11000	660	4400	260

for viscosity > 150mPa.s

Special toothed oval wheels from OaP10 and as standard for Material Design "D2"

OVAL WHEEL METER

SERIES OaP

5. CHARACTERISTIC PARAMETER

5.1 Reference conditions

Bopp & Reuther Messtechnik calibration devices are approved by PTB and traceable to national standards

Pressure: 2 to 7 bar. Temp: 20°C to 30°C

5.2 Accuracy

lin. ± 0,05% to ± 01% of measured value depending on the range of properties of liquid and from the measured value

5.3 Repeatability

< 0,02%

6. CONSTRUCTION DETAILS

6.1 Design / dimensions / weights

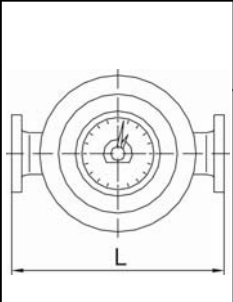
	Type	OaP5	OaP10	OaP50	OaP125	OaP250	OAP600	OaP1200	OaP2000	OaP3200	OaP4000
	Nominal size	DN 25	DN25	DN 50	DN 65	DN 80	DN 100	DN 150	DN 200	DN 300	DN 400
Length L (mm)	DIN PN16/25/ PN40 ANSI150/ ANSI300	220	220	325	450	550	650	800	900	900	1200
	DIN PN100 ANSI600	250	310	400	500	600	700				

For oval wheel meter series OaP only with pulse pick-up AG19, AG20 or AG44 the following dimensions apply

AG19 / AG 20

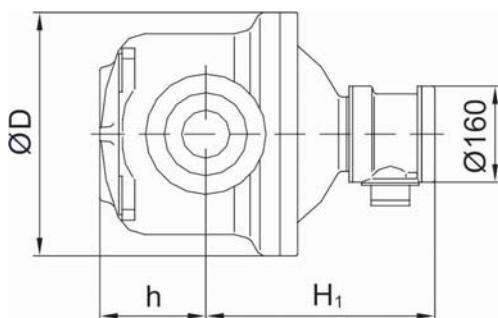

AG 44

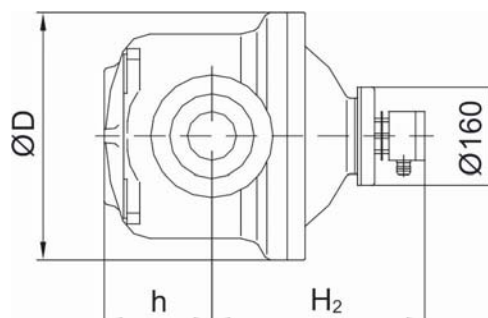

When using a temperature extension, the dimensions H1 and H2 are increased by 300 mm and the weights by approx. 2 kg for DIN PN16,25,40 / ANSI150,300 and for DIN PN100 / ANSI600.

OVAL WHEEL METER

SERIES OaP

Type		OaP5	OaP10	OaP50	OaP125	OaP250	OaP600	OaP1200	OaP2000	OaP3200	OaP4000
Nominal size		DN25	DN25	DN50	DN65	DN80	DN100	DN150	DN200	DN300	DN400
Dimension (mm)	D	144	165	260	320	400	480	614	665	665	665
	h	142	82	104	150	176	258	280	400	658	748
	H ₁	217	296	314	342	382	428,5	482	588	824	914
	H ₂	185	264	282	309	349	396	449	556	792	882
weight approx. (kg)		20	28	62	81	156	261	510	895	1225	1925

Type		OaP5	OaP10	OaP50	OaP125	OaP250	OaP600
Nominal size		DN25	DN25	DN50	DN65	DN80	DN100
Dimension (mm)	D	150	223	292	345	440	505
	H	70	81	121	166	202	278
DIN PN100 ANSI600	H ₁	356	363	381	409	448	495
	H ₂	303	331	349	377	412	463
weight approx. (kg)		29	54	99	141	261	441

OaP 5 – OaP 4000 with universal smart transmitter UST

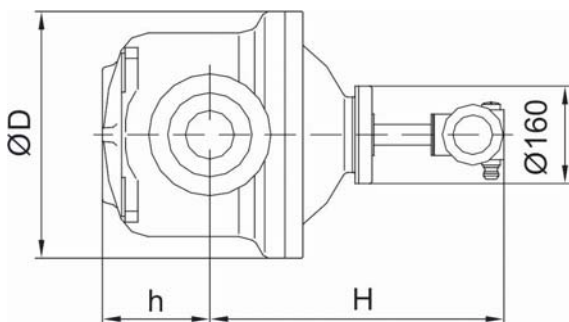

Type		OaP5	OaP10	OaP50	OaP125	OaP250	OaP600	OaP 1200	OaP2000	OaP3200	OaP4000
Nominal size		DN25	DN25	DN50	DN65	DN80	DN100	DN150	DN200	DN300	DN400
Dimension (mm)	D	144	165	260	320	405	480	614	665	665	665
	h	142	82	104	150	176	258	280	400	658	748
	H USTI / USTX	340	419	437	464	504	551	604	711	947	1037
	H USTD	328	407	425	452	492	539	592	699	935	1025
weight approx. (kg)		19	27	61	80	155	260	509	894	1224	1924

OVAL WHEEL METER

SERIES OaP

Type		OaP5	OaP10	OaP50	OaP125	OaP250	OaP600
Nominal size		DN25	DN25	DN50	DN65	DN80	DN100
Dimension (mm)	D	150	223	292	345	440	505
	h	70	81	121	166	202	278
	H USTI / USTX	479	486	503	532	571	618
	H USTD	467	474	491	520	559	606
weight approx. (kg)		28	53	98	140	260	440

OaP5 - OaP400 with mechanical indicator E,D or roller counter M5 and optional pulse pick-up AG19, AG20, AG01-08
Version with single indicator E and double indicator D

OaP ... E / OaP ... D	OaP ... Es / OaP ... Ds	OaP ... wE / OaP ... wD

Version with roller counter M5

OaP ... M5	OaP ... M5s

Version with roller counter M5V

OaP ... M5V (with pneumatical switch or electrical switch e2)	OaP ... M5sV

OVAL WHEEL METER

SERIES OaP

Type		OaP5	OaP10	OaP50	OaP125	OaP250	OaP600	OaP 1200	OaP2000	OaP3200	OaP4000
Nominal size		DN25	DN25	DN50	DN65	DN80	DN100	DN150	DN200	DN300	DN400
D (mm)		144	165	260	320	405	480	614	665	665	665
Dimension (mm)	h	142	82	104	150	176	258	280	400	658	748
	H1	235	314	332	358	399	446	499	606	842	932
	H2	315	394	412	438	479	526	579	686	922	1012
	H3	360	439	457	483	524	571	624	731	967	1057
	H4	365	444	462	488	529	576	629	736	972	1062
	H5	395	474	492	518	559	606	659	766	1002	1092
	H6	370	449	467	493	534	581	657	741	977	1067
weight approx. (kg)	E,D	19	27	61	80	155	260	509	894	1224	1924
	M5	25	33	67	86	161	266	515	900	1230	1930
	M5V	32	40	74	93	168	273	522	907	1237	1937

DIN PN100 / ANSI600

Type		OaP5	OaP10	OaP50	OaP125	OaP250	OaP600
Nominal size		DN25	DN25	DN50	DN65	DN80	DN100
D (mm)		150	223	292	345	440	505
Dimension (mm)	h	70	81	121	166	202	278
	H1	374	381	398	427	466	513
	H2	454	461	478	507	546	593
	H3	499	506	523	552	591	638
	H4	504	511	528	557	596	643
	H5	534	541	558	587	626	673
	H6	509	516	533	562	601	648
weight approx. (kg)	E,D	28	53	98	140	260	440
	M5	34	59	104	146	266	446
	M5V	41	66	111	153	273	453

Regardless of the flange pressure rating, external meters, pulse pick-up AG19 / AG20 or extension, dimensions H1 to H7 change as follows:

External regulation
+ 42 mm

Pulse pick-up AG19
+ 115 mm

Pulse pick-up AG20

Pulse pick-up AG01-08
+115 mm

Extension
+300 mm

When using a temperature extension of 300 mm, the weight is increased by approx. 2 kg

OVAL WHEEL METER

SERIES OaP

6.2 Material

	L2	D2	G2
Housing	Cast steel	Cast steel	Cast steel
Chamber	Aluminum	Cast iron	Cast iron
Oval wheels	Aluminum	Cast iron	Cast iron
Bearing	Hard carbon	Cast iron	Hard carbon

Available materials

	L2	D2	G2
OaP 5	in planning	•	on request
OaP 10	in planning	•	on request
OaP 50	in planning	•	on request
OaP 125	•	•	on request
OaP 250	•	•	on request
OaP 600	•	•	•
OaP1200	•	•	on request
OaP 2000	in planning	•	on request
OaP 3200	in planning	•	on request
OaP 4000	in planning	•	on request

OVAL WHEEL METER

SERIES OaP

7. OPERATING CONDITIONS

7.1 Degree of protection

	ambient temperature	Housing	Ex-protection
OaP:			Mech. Ex. Protection see certificate of conformity
AG19, AG20:	-25 to +90°C	IP54	II 2G Ex ia IIC T6
AG44 :	-50 to +60/+75/+85°C	IP65	II 2G Ex ib IIC T6/5/4
AG01-08	-30 to +70°C	IP67	II 2G Ex d II BT6Gb
Indicator E, D :	-20 to +110°C	IP54	
M5:	-20 to +60°C	IP54	
M5 accessories:			see D-DE-17205-00
USTI:	-20 to +70°C	IP65	II 1/2G Ex ia IIC T4
USTX:	-40 to +60°C	IP65	II 2G Ex d [ib] IIC T4
USTD:	-40 to +60°C	IP65	II 2G Ex d [ia] IIC/IIB T6

Degree of protection for housing IP acc. IEC 60529 / EN 60529, Ex-approval directive 2014/34/EU
Attention: the LC-display of the electrical counter (UST) works from -10°C to +70°C

7.2 Process pressure process connection

Nominal pressure*	PN25 DIN2544	PN40 DIN2545	PN100 DIN2547	ANSI150 ⁽¹⁾	ANSI300 ⁽²⁾	ANSI600 ⁽³⁾
OaP 5		L2**-D2	L2**-D2	L2**-D2	L2**-D2	D2
OaP 10		L2**-D2	L2**-D2	L2**-D2	L2**-D2	D2
OaP 50		L2**-D2	L2**-D2	L2**-D2	L2**-D2	D2
OaP 125		L2--D2	L2-D2	L2-D2	L2-D2	L2-D2
OaP 250		L2-D2	L2-D2	L2-D2	L2-D2	L2-D2
OaP 600		L2-D2-G2	L2-D2-G2	L2-D2-G2	L2-D2-G2	L2-D2-G2
OaP 1200		L2-D2		L2-D2	L2-D2	
OaP 2000	L2**-D2	L2**-D2		L2**-D2	L2-D2	
OaP 3200	L2**-D2	D2		L2**-D2	L2**-D2	
OaP 4000	L2**-D2			L2**-D2	L2**-D2	

*at measurement temperature lower than -10°C and over than 50°C pay attention to pressure reduction!
** in planning

- (1) Flange drilled acc. to ANSI150 though housing acc.to DIN PN25, 40 depended on material
- (2) Flange drilled acc. to ANSI300 though housing acc.to DIN PN25, 40 depended on material
- (3) Flange drilled acc. to ANSI600 though housing acc.to DIN PN100 depended on material

OVAL WHEEL METER

SERIES OaP

7.3 Operating temperature limit

Available materials see chapter 6.2

OaP L2	-10 to 60°C
OaP mech. Indicator	Standard
OaP AG19/AG20/AG01-08	
OaP AG44	
OaP AG44 UST	

OaP D2	-10 to 90°C	>90 to 110°C	>110 to 170°C	>110 to 290°C
OaP mech. Indicator	Standard	Extension	Extension + high temperature.-magnetic coupling	
OaP AG19/AG20/AG01-08				
OaP AG44			Extension+high temperature pulse pick-up	
OaP AG44 UST			high temperature pulse pick-up	

Special toothed oval wheels as standard for material D2

OaP G2	-10 to 90°C	>90 to 110°C	>110 to 170°C	>110 to 230°C
OaP mech. indicator	Standard	Special tolerances	Extension + special tolerances High temperature magnetic coupling	
OaP AG19/AG20/AG01-08		Extension+ Special tolerances		
OaP AG44		Special tolerances	Extension+special tolerances+high temperature pulse pick-up	
OaP AG44 UST			High temperature pulse pick-up	

For liquefied gases with special tolerances max. 20°C. (version D2 not suitable)
 OaP with mechanical indicator or AG19/AG20/AG01-08 with extension 400 mm and 2. magnetic coupling available to -60°C (pay attention to pressure reduction).
 OaP AG44 with and without UST with special tolerances, special bolts and nuts to -40°C (pay attention to pressure reduction).

OVAL WHEEL METER

SERIES OaP

7.4 Pressure loss

Standard toothed oval wheels

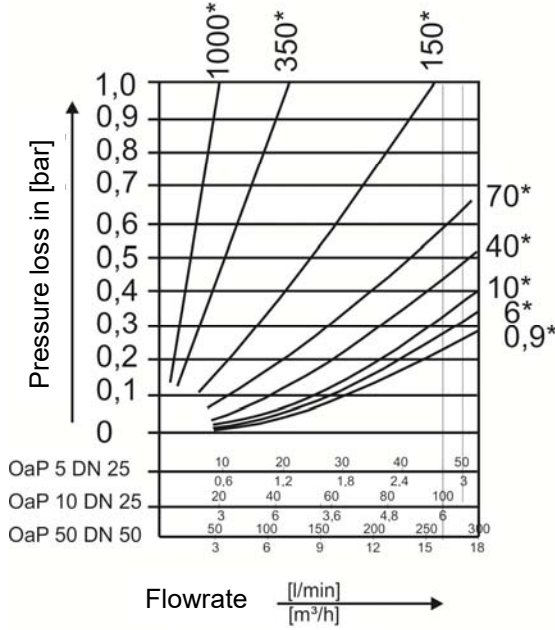

special toothed oval wheels

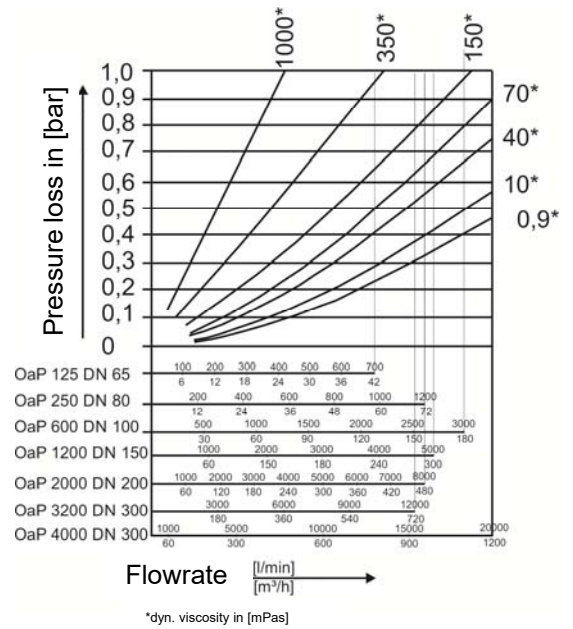
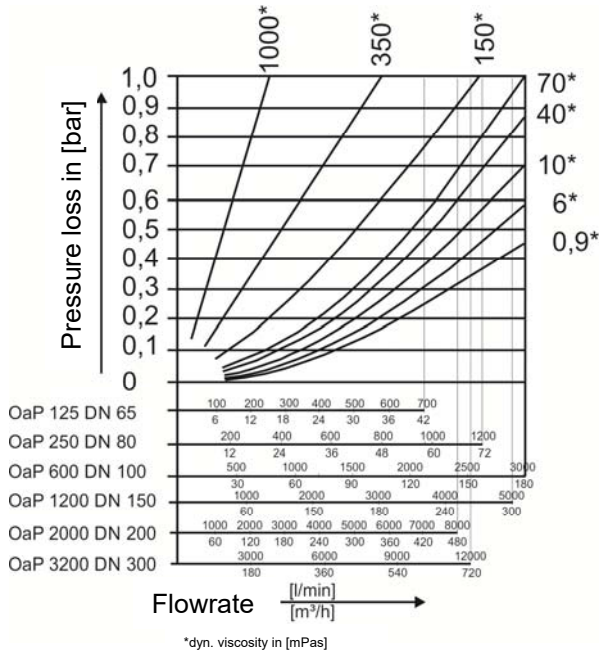
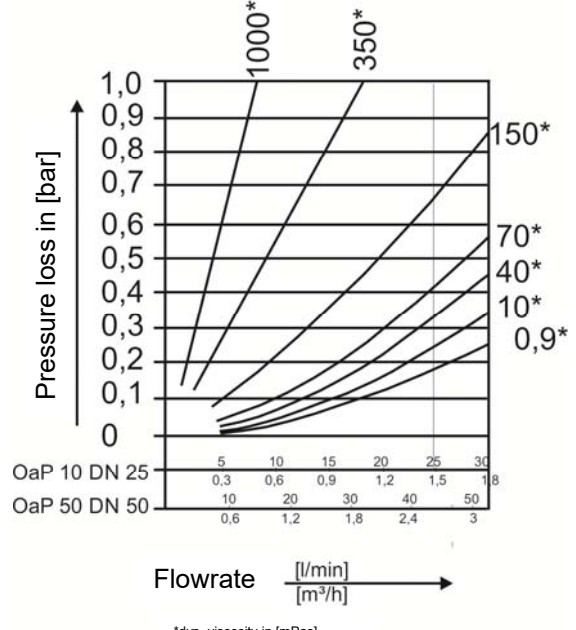

OVAL WHEEL METER

SERIES OoP

8. CERTIFICATES AND APPROVALS

**EC-certificate of conformity,
Bopp & Reuther Messtechnik GmbH**

EC-Examination Certificate**Directive 2014/34/EU (Ex-Directive), IEC-Ex**

DIN EN ISO80079-36 : non-electrical equipment for use in potentially explosive atmospheres

EN 1127-1: Ex-protection, basic concepts and methodology

EN 60079-0: Electrical equipment for gas explosion hazard areas– general requirements

EN 60079-11: intrinsically safety „i“

EN 60079-1: flameproof enclosures „d“

- Universal Smart Transmitter Typ UST Exia
DMT 99 ATEX E 014 X
- Universal Smart Transmitter Typ UST Exd [ia]
DMT 00 ATEX E 025 X
- Universal Smart Transmitter Typ UST Exd [ib]
BVS 04 ATEX E 022 X
- Pulse pick-up AG19, AG20 (proximity switch types SJ 3,5N)
PTB 99 ATEX 2219 X
- Pulse pick-up AG01-08 (shaft encoder 01-08)
TÜV 15 ATEX 131621 X
- Pules pick-up AG44 (Wiegand Sensor with
preamplifier Type PV11)
DMT 00 ATEX E 063 X

Directive 2014/30/EU (EMC-Electromagnetic compatibility)

- EN 61000-6-2: generic standards – immunity for industrial environments
- EN 61000-6-3: generic standards – emission standard for residential, commercial and light-industrial environments

Directive 2014/68/EU (PED-Pressure Equipment Directive)

- DIN EN 10213
- AD 2000 Rulebook
- EC-type approvals module B + C1

**CUSTODY APPROVAL ACC. TO GERMAN AND EUROPEAN
MEASURING EQUIPMENT DIRECTIVE - MID**

EC approval, Measuring Instrument Directive MID 2014/32/EU
OIML R117 Test reports

OTHER STANDARDS, APPROVALS AND CERTIFICATES

EN 55011: Industrial, scientific and medical (ISM) radio-frequency equipment, electromagnetic disturbance characteristics. Limits and methods of measurement

NAMUR NE 21: Electromagnetic compatibility (EMC) of industrial process and laboratory control equipment

EN 61010-1: Safety requirements for electrical equipment for measurement, control and laboratory use – general requirements

EN 60947-5-6: Specification for low-voltage switchgear and controlgear. Control circuit devices and switching elements. DC interface for proximity sensors and interface for proximity sensors and switching amplifiers (NAMUR)

SIL2: OaP AG19X, OaP AG20X acc. IEC 61508:1999

Lloyds Register, Rostechndador**CE-Mark:**

The measuring system complies with the legal requirements of the EC Directives 2014/30/EU, 2014/34/EU, 2014/68/EU und 2011/65/EU, including the amendments and supplements published to date. Bopp & Reuther Messtechnik GmbH confirms the successful testing of the device by affixing the CE mark

9. DOCUMENTATION

Manuals

A-EN-01221-00 Manual OaP with pulse pick-up and / or mechanical counters
A-EN-01222-10 Manual OaP with Universal Smart Transmitter UST (Ex i)
A-EN-01222-DX Manual OaP with Universal Smart Transmitter USTD / USTX (Ex d)

Accessories

D-EN-17202-00 Pulse pick-up AG19 and AG20
D-EN-17230-00 Pulse pick-up AG01-08
D-EN-17201-00 Pulse pick-up AG4x
D-EN-17205-00 Single indicator E and double indicator D
D-EN-17205-00 Mechanical resettable roller counter, series M5
D-EN-17207-00 Universal Smart Transmitter UST