

DENSITY- AND CONCENTRATION METER

SERIES DIMF

1. IDENTIFICATION

Manufacturer Bopp & Reuther Messtechnik
 Am Neuen Rheinhafen 4
 67346 Speyer / Germany
 Phone: +49 6232 657-0
 Telefax: +49 6232 657-505

Product type Vibrating element, Density Meter

Product name Density Meter, Series DIMF

2. RANGE OF APPLICATION

The liquid density meter of the DIMF series is used for continuous measurement of the density / concentration of liquids or liquid mixtures.

The proven tuning fork principle guarantees a high measuring accuracy with very good long-term stability. The robust design ensures reliable operation even under harsh operating conditions.

3. MEASURING PRINCIPLE AND SYSTEM CONFIGURATION

3.1 Measuring principle

The actual transducer of the device is a vibrating element. The liquid flows continuously through the vibrating element. The frequency of the vibrating element is used as a measure of the density; its natural frequency depends on the density of the liquid absorbed. The oscillations are excited and scanned electromagnetically. An additional built-in resistance thermometer is used to measure the measuring temperature, which can also be used to compensate for the influence of

temperature. Each device is calibrated with liquids of different densities. The transducer constants for calculating the density from the frequency, the calibration temperature and the correction coefficients for the temperature influence can be found in the protocol of the configuration data.



DIMF 2.1



DIMF 2.0



DIMF 1.3

DENSITY- AND CONCENTRATION METER

SERIES DIMF

3.2 System Configuration

Transducer:

DIMF 1.3	Hollow tuning fork
DIMF 2.0 / 2.1	Vibrating element in the form of a Tuning fork bent tube

Preamplifier PVS and PKS

Output: frequency dependent on operating density, not linearized, modulated to supply current, duty cycle 1:1, approx. 700 to 1400 Hz depending on transducer type; linearization and temperature correction in the computer

Power supply:

24 VDC (min. 15 VDC / max. 30 VDC) intrinsically safe
Seal connection 2-wire connection via screw terminals and cable gland M20x1,5

Temperature connection:

In 4-wire technology via screw terminals and cable gland M20x1.5 (Pt 100 installed in DIMF)

Cable specification:

Two or four wires twisted in pairs and shielded

Transmitter TVS, TWS und TWH

Output signal:

4-20 mA, linearized and temperature corrected, can be assigned to any desired display value, e.g. operating density, reference density, concentration, Brix, Plato or other values derived from the density.

Power supply:

24 VDC (min. 16 VDC / max. 30 VDC)

Connection:

2-wire technology via screw terminals; cable entry via cable gland with M20x1.5 or 1/2" NPT thread for pipe installation (conduit system)

Cable specification:

Two-core twisted and shielded

Display values:

density, concentration, operating temperature, etc.

Designs:

- V Composite version with directly mounted transmitter
- K Compact version (only with preamplifier "P" in conjunction with threaded connection)
- W separate version with separate transmitter for wall mounting with 1.5 m cable
- S Temperature version: -40 to +150°C
- H High temperature: -40 up to +210°C, only for transmitter "T" in combination with option "W".

DENSITY- AND CONCENTRATION METER

SERIES DIMF

4. Input

	DIMF 1.3	DIMF 2.0	DIMF 2.1
Density range	400 to 3000 kg/m ³		
Calibration range	400 to 1450 kg/m ³		
Accuracy	better than ±0.01 %	better than ±0.02 %	better than ±0.02 %
		better than ±0,01 % with special calibration (after request on special applications)	
Repeatability	better than ±0.005 %	better than ±0.005 %	better than ±0.005 %

DENSITY- AND CONCENTRATION METER

SERIES DIMF

5. CONSTRUCTION DETAILS

5.1 Design / dimensions

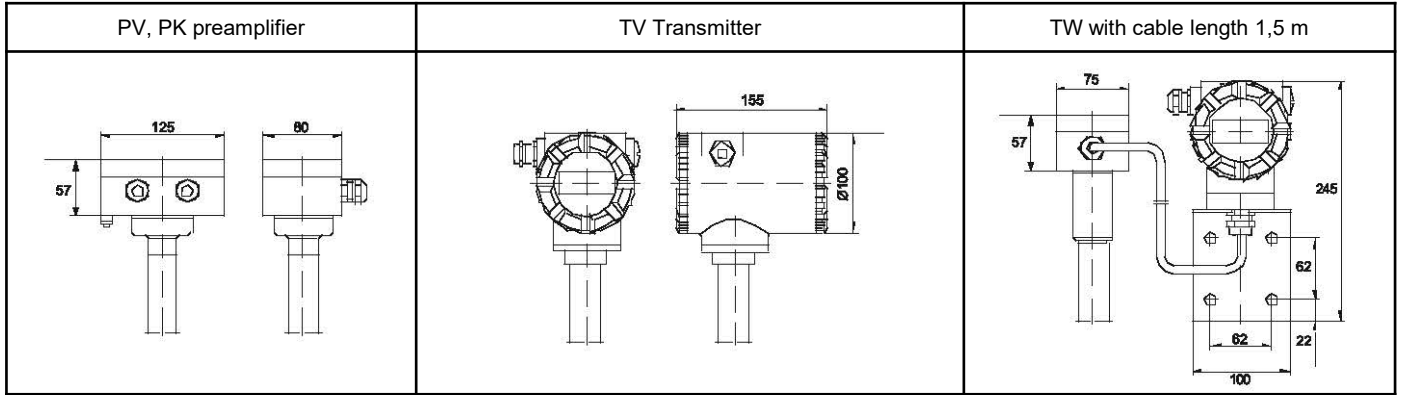

DIMF 1.3

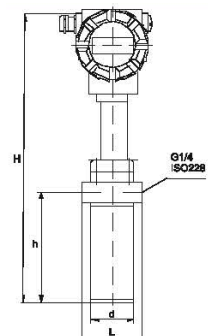
	Dimensions (mm)		DIMF 1.3 PV	DIMF 1.3 PK	DIMF 1.3 TV	DIMF 1.3 TW
	Length by connection type (L)					
	Female thread	Flange				
	82	200				
			H	374	241	412
		h	155	155	155	155
		d	60,3	60,3	60,3	60,3

DIMF 2.0 / 2.1

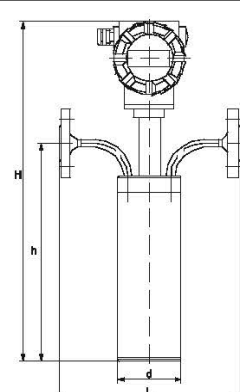
	Dimensions (mm)		DIMF 2.0 PV	DIMF 2.0 TV	DIMF 2.0 TW	DIMF 2.1 PV	DIMF 2.1 TV	DIMF 2.1 TW
	Length by connection type (L)							
	Swagelok, food version	Flange						
	250	250						
	DIMF 2.1 only Flange version L=450 mm		H	430	468	464	776	814
		h	301	301	301	643	643	643
		d	88,9	88,9	88,9	219,1	219,1	219,1

DENSITY- AND CONCENTRATION METER

SERIES DIMF

5.2 Material

	DIMF 1.3	DIMF 2.0	DIMF 2.1
Material of wetted parts	Special alloy of NiFeCr and 1.4571	Stainless steel 1.4571 (SS316Ti) Stainless steel 1.4306 (SS304L) Hastelloy C4 (2.4610) Hastelloy B2 (2.4617) Tantalum (2.6051.9) Inconel 600 (2.4816.10) Monel 400 (2.4360)	Stainless steel 1.4571 (SS316Ti) others on request
Material sensor housing	Stainless steel (SS316)		
Special features	Version without seal		

Attention: see chapter 6.2 available connection type

6. OPERATING CONDITIONS

6.1 Degree of protection

Europa (CE)

	ambient temperature	Housing
DIMF 1.3, 2.0, 2.1 T Ex i :	-40 to +58°C	IP67
DIMF 1.3, 2.0, 2.1 T Ex d :	-40 to +58°C	IP67
DIMF 1.3, 2.0, 2.1 P Ex i :	-50 to +70 / +85°C	IP65
DIMF 1.3 P Ex d :	-40 to +60°C	IP65

Protection class Housing IP according to IEC 529 / EN 60529, Ex-approval Directive 2014/34/EU

Attention: The LC-Display of the Transmitter TV works from -10°C to +70°C. Tantalum version with TVS Ex i II2G Ex ia IIC T4

Eurasian Economic and Customs Union (EAC)

	Ambient temperature	Housing
DIMF1.3T**-I, DIMF2.0T**-I, DIMF2.1T**-I	-40 bis +58°C	IP67
DIMF1.3T**-X, DIMF2.0T**-X	-40 bis +58°C	IP67
DIMF1.3PV*-I	-50 bis +70 / +85°C	IP65
DIMF1.3PV*-D	-40 bis +60°C	IP65
DIMF2.0PV*-D	-40 bis +60°C	IP65

DENSITY- AND CONCENTRATION METER

SERIES DIMF

6.2 Medium pressure limit - process connection

	DIMF 1.3	DIMF 2.0	DIMF 2.1
Medium pressure limit	up to max. 100 bar depending on process connection	160 bar	40 bar
Process connection	<p>Female thread G$\frac{1}{4}$ according to ISO 228</p> <p>Flange version according to DIN 2545: DN10 PN 40</p> <p>Flange version according to DIN 2547: DN10 PN100</p> <p>Flange version according to ANSI B 16.5: $\frac{1}{2}$" ANSI150 RF $\frac{1}{2}$" ANSI300 RF $\frac{1}{2}$" ANSI600 RF</p>	<p>Swagelok for outside tube diameter 12 mm</p> <p>Food connection Aseptic-threaded socket (IDN11864): Rd 28 1/8 PN16 NAUE DN10 PN16 Threaded socket (DIN11851): Rd28 1/8 PN10 TRI-Clamp (DIN32676) DN15 PN16</p> <p>Flange version according to DIN 2545: DN15 PN 40 DN25 PN40</p> <p>Flange version according to DIN 2547: DN15 PN100 DN25 PN100 DN25 PN160</p> <p>Flange version according to ANSI B 16.5: $\frac{1}{2}$" ANSI150 RF $\frac{1}{2}$" ANSI300 RF $\frac{1}{2}$" ANSI600RF 1" ANSI150 RF 1" ANSI300 RF 1" ANSI600 RF 1" ANSI1500 RF (PN160)</p>	<p>Flange version according to DIN EN 1091: DN25 PN40 DN50 PN 40</p> <p>Flange version according to ANSI B 16.5: 1" ANSI150 RF 1" ANSI300 RF 2" ANSI150 RF 2" ANSI300 RF</p>

Attention: DIMF 1.3 with flanges is only available in V or W version
 DIMF 2.0 with Swagelok or food connection only available in stainless steel 1.4571, stainless steel 1.4306 or Hastelloy C4
 DIMF 2.0 with NAUE-fitting and TRI-Clamp-connection only available in stainless steel 1.4571

DENSITY- AND CONCENTRATION METER

SERIES DIMF

6.3 Temperature limit of the medium

	DIMF 1.3	DIMF 2.0	DIMF 2.1
Temperature of the medium	-40° to +100°C	-40° to +150°C (High temperature to +210°C)	-40° to +150°C

6.4 Flow range and pressure loss

	Flow in l/min		Pressure loss in bar (H ₂ O, 20°C)
	Suggestions	Limits	
DIMF 1.3	0.3 to 1	0 to 10	1 l/min : 0.015
DIMF 2.0	1.5 to 6	0 to 50	6 l/min : 0.04
DIMF 2.1	20 to 50	0 to 350	50 l/min : 0.025

DENSITY- AND CONCENTRATION METER

SERIES DIMF

7. CERTIFICATES AND APPROVALS

EG-Conformity declaration,
Bopp & Reuther Messtechnik GmbH

EC type-examination certificate

Directive 2014/30/EU (EMC-Electromagnetic compatibility)

- EN 61000-6-2: generic standards – immunity for industrial environments
- EN 61000-6-3: generic standards – emission standard for residential, commercial and light-industrial environments

Directive 2014/68/EU (PED-Pressure Equipment Directive)

- Sound engineering practice acc. to article 4 paragraph 3
- AD 2000 Code

CUSTODY APPROVAL ACC. TO GERMAN AND EUROPEAN MEASURING EQUIPMENT DIRECTIVE - MID
EC approval, Measuring Instrument Directive MID 2014/32/EU
OIML R117 Test reports

OTHER STANDARDS, APPROVALS AND CERTIFICATES

GOST approvals

Ex-approvals Eurasian Economic and Customs Union (EAC) No. TC RU C-DE.AA87.B.01188 Series RU No. 0743831

Measuring equipment approval Russia No. 79340-20

Measuring equipment approval Belarus No. 10795

CE-Mark

The measuring system complies with the legal requirements of the EC Directives 2014/30 / EU and 2014/34 / EU, including the amendments and supplements published to date. Bopp & Reuther Messtechnik GmbH confirms the successful testing of the device by affixing the CE mark.

8. DOCUMENTATION

Manuals

A-EN-06530-00 Manual Density and concentration meter DIMF 1.3 TVS, DIMF 2.0 TVS and DIMF 2.1 TVS

A-EN-06130-00 Manual Density and concentration meter DIMF 1.3 PV, DIMF 2.0 PV and DIMF 2.1 PV