

MASS FLOWMETER TRANSDUCER FME 26



MAIN CHARACTERISTICS

| | |
|-----------------------|---|
| Product Type: | Mass flowmeter transducer FME 26 |
| Application: | for direct mass measurement of liquids |
| Ex-approval: | Usage in safe area, transducers in zone 1 can be connected |
| IP protection: | IP20, IP54 (front only) |
| Ambient temperature: | -20°C up to +60°C |
| Housing installation: | Panel, DIN-Rail |
| Housing material: | Noryl |
| Power supply: | 10 – 28 VDC or 100 – 240 VAC |
| Process supply: | 1 x 4-20 mA, RS 485 / Modbus, 2 x pulse / frequency / status |
| Input: | digital input 24 VDC |
| Display: | LCD with backlight |
| Weight: | 0.55 kg |
| Special features: | Colour change of the display for indication of warnings or errors |

DESIGN / DIMENSIONS

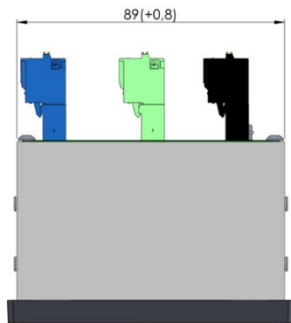
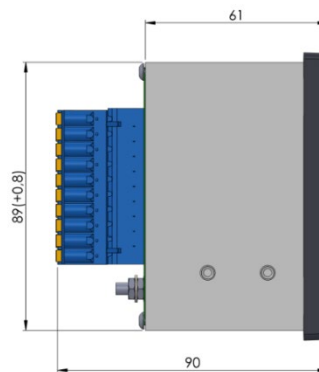
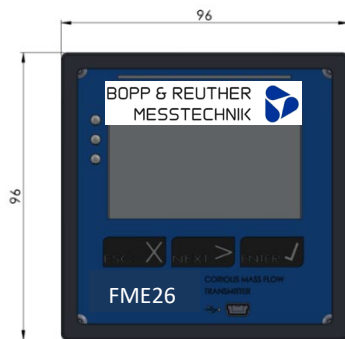

CONNECTION

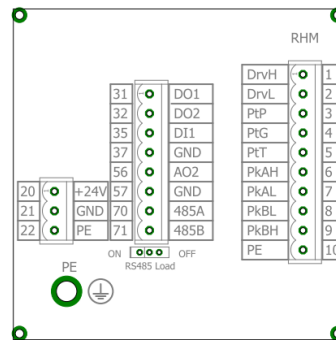

COMPATIBLE

Coriolis transducer Type FMO

Further information and product variants are available on request

